

Series 220

SHOP DRAWINGS

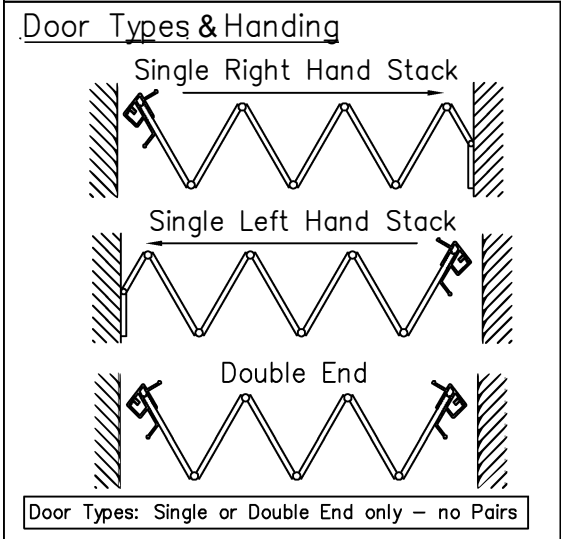
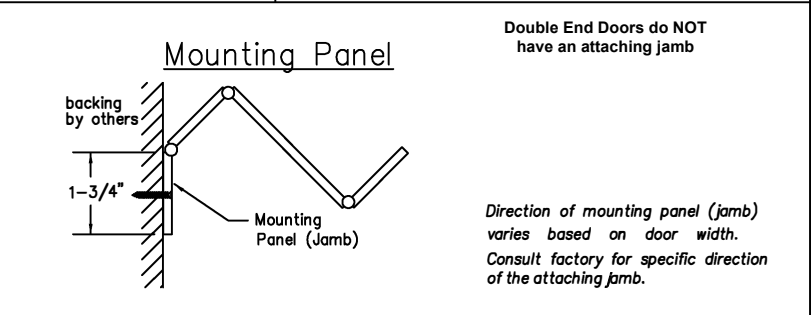
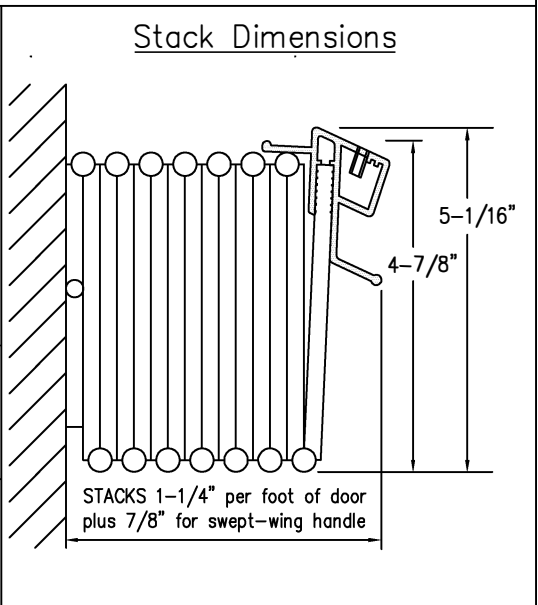
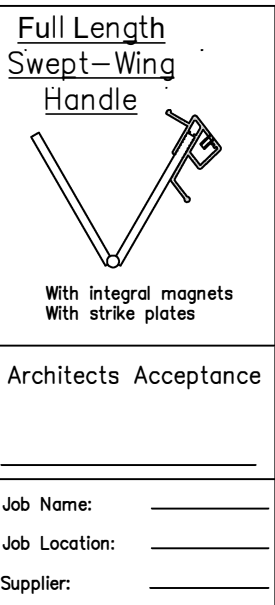
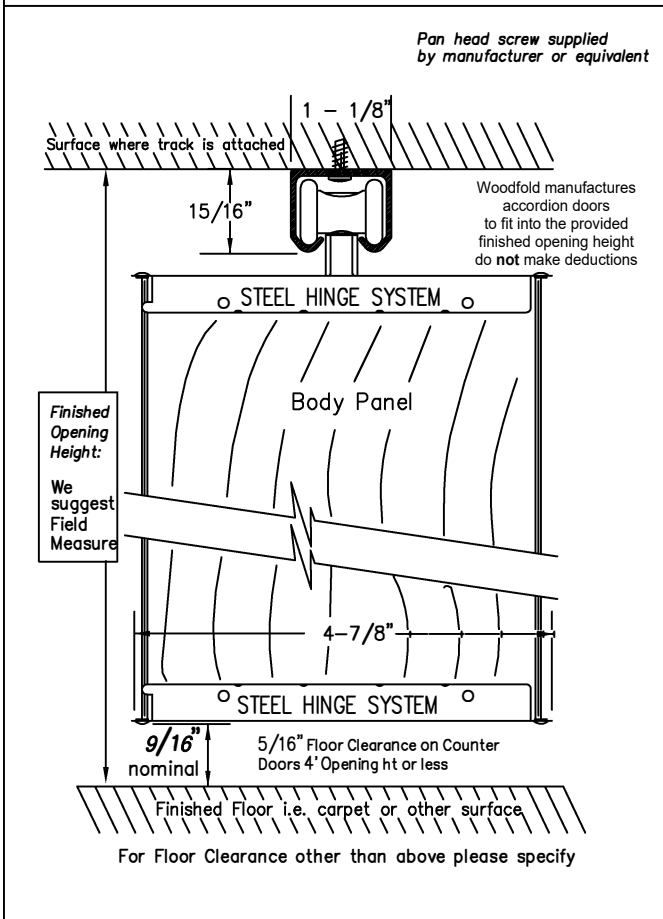

INFORMATION

Opening Width	Custom made up to 8' - 0"
Opening Height	Custom made up to 8' - 1"
Panels	Natural hardwood veneer or vinyl-lam on MDF core
Panel Connector	Connector: White, Black, Brown, Gray or Sand
Hinge System	Hinge hardware: Dark Bronze or Silver Finish
Wheels	Nylon wheels on lexan axles
Track	Aluminum (straight only): Bronze or Silver
Swept Wing Handle	White, Black, Brown, Gray or Sand coordinated with panel connector.
Catch	Dual Magnets with strike plates
Header	Construction Detail by Others

	<u>Height</u>	<u>Average Weight</u>
Door Weight	6'-10"	10lbs. Per lineal foot
	8'-1"	12lbs. Per lineal foot

See Woodfold Accordion Door brochure and Specifications for more details

Qty.	Single End/Double End	Left or Right Stack	Width X Height	Material	Finish/Color	Options

THESE SPECIFICATIONS ARE SUBJECT TO CHANGE WITHOUT NOTICE

Woodfold Mfg. Inc.
1811 18th Ave Forest Grove, OR. 97116
http://www.woodfold.com

Phone: 503-357-7181
Email: woodfold@woodfold.com