

### Surface Track

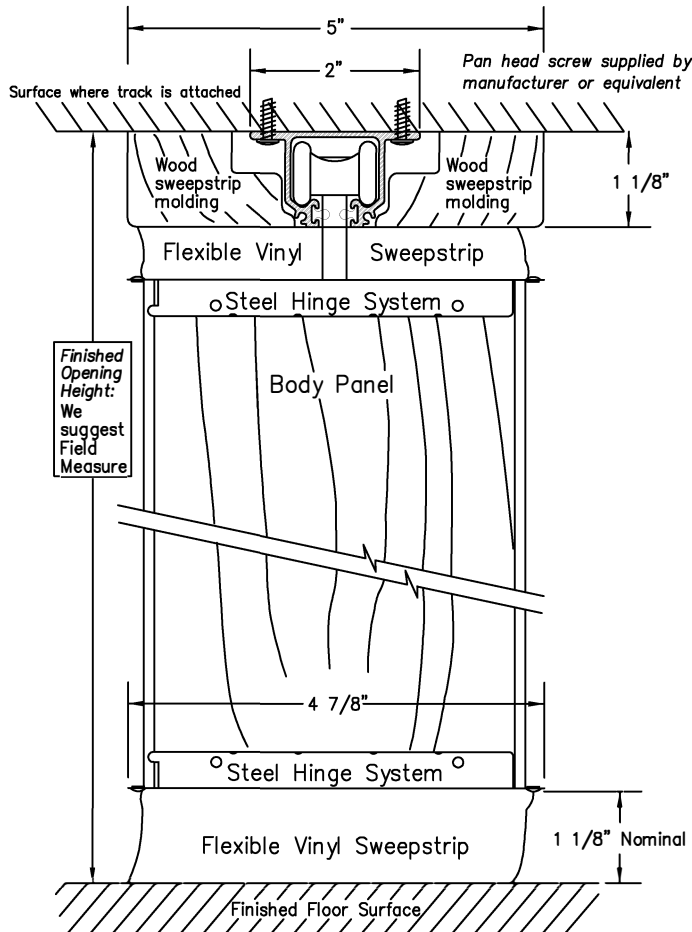

### Sliding Jamb Option

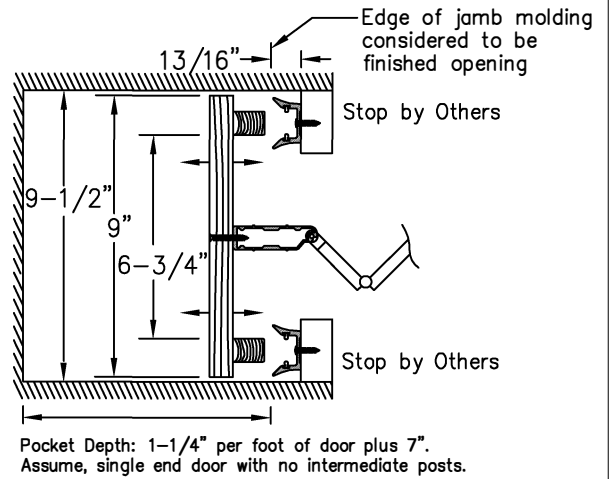

### Lead Post, Jamb Moulding & Handle

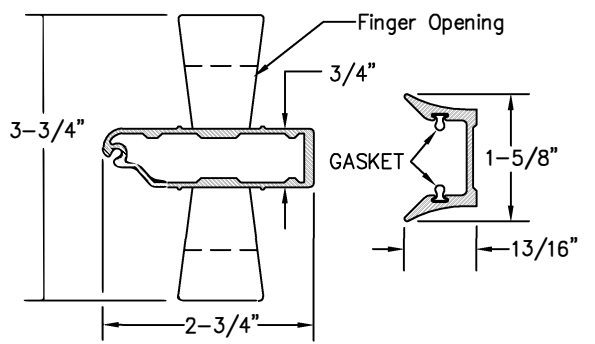

### Door Types

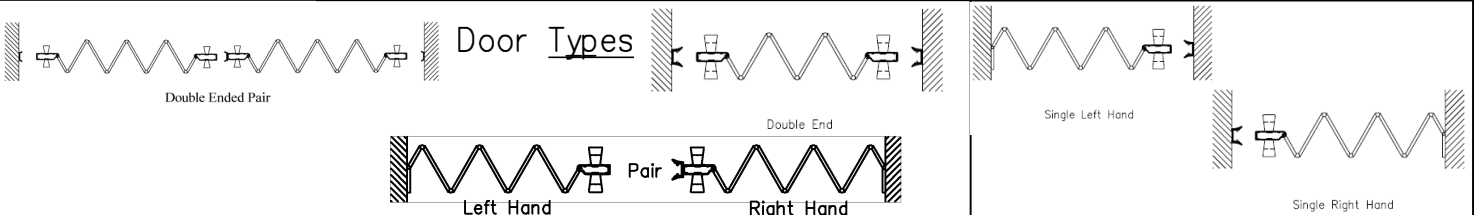

### Stack Dimensions

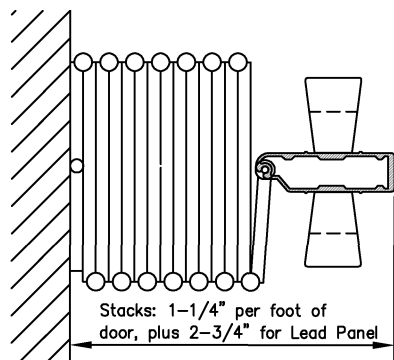

### Mounting Panel

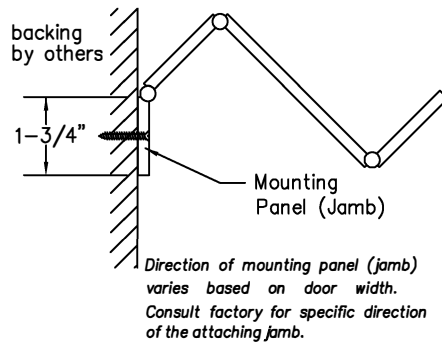

### Multiple Meeting Option

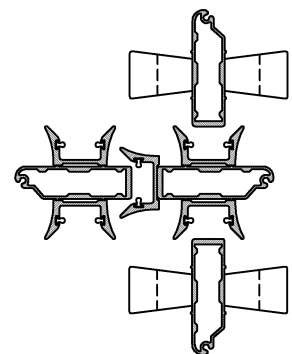

Intermediate Posts add 4" to Stack  
Each Lead Post adds 2-3/4" to Stack

**Intermediate Rolling Post**

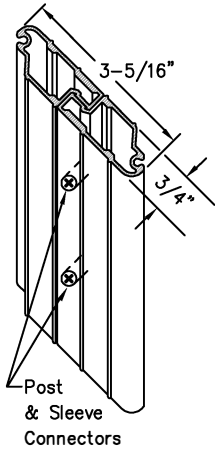

Required at 30'-0"

**Privacy Latch**

Thumbturn on both sides is standard



**Keylock**

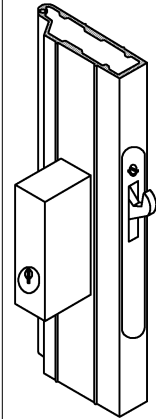

**Single Cremone Bolt Keylock**

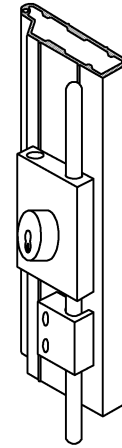

**Double Cremone Bolt Key Lock**

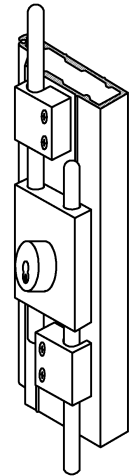

**INFORMATION**

Opening Width: Widths up to 30'-0" without Intermediate Posts  
 Opening Height: Custom made up to 10' -1"  
 Panels: Natural hardwood or vinyl-lam on MDF core 1/4" thick  
 Panel Connectors: Extruded Vinyl Black, Brown Gray, Sand or White  
 Hinge Hardware: Bronze or Silver  
 Wheels: Ball bearing nylon wheels on steel axes (I-Beam for Curved Option)  
 Track Aluminum (straight or curvable): Bronze or Silver  
 Recessed Hat Channel: Aluminum (straight only): White  
 Lead Post, Interlocking jamb & Intermediate Post:  
 Black, Bronze, Silver, Sand or White Coordinated with panel connector  
 Latch: Deadlatch with thumb turn two sides  
 Header: Constructions Details by Others

Height	Average Weight
6'-8"	10lbs. Per lined foot
8'-1"	12lbs. Per lined foot
10'-1"	15lbs. Per lined foot

Sweepstrips: 1" or 2" Brown, Gray or White  
 Wood Moldings provided in White or Brown only

**Catch/Lock Options**

Magnet	Magnet with strike plate centered at handle
Privacy Latch	Thumbturn w/Emergency release opposite side
Springlatch	Springlatch with thumb turn two sides
Keylock 1 Side	Deadlatch with thumb turn one side, keylock one side
Keylock 2 Side	Deadlatch with keylock two sides
Single Cremone	Single cremone with keylock (can't be keyed to match door lock)
Double Cremone	Double cremone with keylock (can't be keyed to match door lock)
Footbolts	Drop Bolt or Spring Pin Bolt
Keylock Options	Weiser Cylinder 6-Pin (Standard), Schlage 5-Pin cylinder or BEST Construction core to be keyed on site by others to match existing job

Job Name: \_\_\_\_\_  
 Job Location: \_\_\_\_\_  
 Supplier: \_\_\_\_\_

Architects Acceptance

See Woodfold Accordion Door brochure for additional details

Qty.	Single/Pair	Single End/Double End	Left or Right Stack	Width X Height	Finish/Color	Options

THESE SPECIFICATIONS ARE SUBJECT TO CHANGE WITHOUT NOTICE