



4100 SERIES ACOUSTICAL FOLDING PARTITION

INSTALLATION INSTRUCTIONS - READ CAREFULLY

The acoustical effectiveness of your Woodfold 4100 series depends greatly upon surrounding construction and care of installation. Surrounding construction shall have a sound rating that equals or exceeds the sound rating of the Woodfold 4100 series.

All sides of the opening shall be prepared to a high degree of level and plumb. The partitions are heavy; approx. weight 7lbs per sq ft. A header capable of supporting this weight without deflection must be provided by others. Also an adequate number of personnel and proper equipment must be provided for proper handling during installation.

Fabrication height is measured from finished floor (or floor covering) to header where the track will be secured. This measurement is critical and must be maintained across the entire opening width.

Job-Site measurement shall be carefully checked against fabrication height dimension shown on packing slip before proceeding.

SECTION 1

Installation of Single Partitions

Partition track is pre-punched and #14 x 2" Panhead sheet metal screws are provided. For simplicity we have used 'track' to describe both regular track and the Ceiling Guard option.

Should other screws or fasteners be used, the head size must be not larger than those provided.

STEP 1

- A. Mark and pre-drill header to match holes in track. Extreme care shall be taken to prevent shavings or any other foreign material getting into track.

DO NOT DRILL THRU TRACK

If more than one track section is supplied, care must be taken where the two track ends meet to secure them to the header in precise alignment to assure smooth, trouble-free travel of the carriers.



CAUTION:
NEVER STORE ON END
Keep in crate until ready to install

STEP 1 (Cont'd)

B. Remove Top Panel from crate. - All screws

Remove End Panel. - All screws



C. Remove End Cap. - **Do not remove** the screws marked 'X' in this image



D. Continue around end cap removing remaining screws as necessary - **Do not remove** the screws marked 'X' in this image.

Note: Crate size determines the number of screws used.



E. Slide end cap off - exposing wheels



F. Main crate should not be removed until the partition is suspended on the track. Carefully stand the assembly on the base with the top wheels directly beneath the track location.

G. Thread track onto wheels and begin installing track screws at the far end. Secure enough screws to support the assembly in a partially extended position. Remove remaining crate and inner packing. Carefully move the assembly to the secured portion of the track. Install remaining screws.

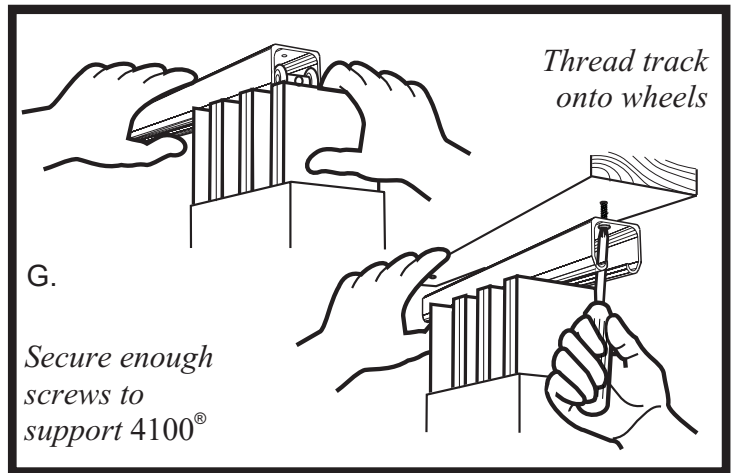

Surface Track with wood molding
(4166 shown)

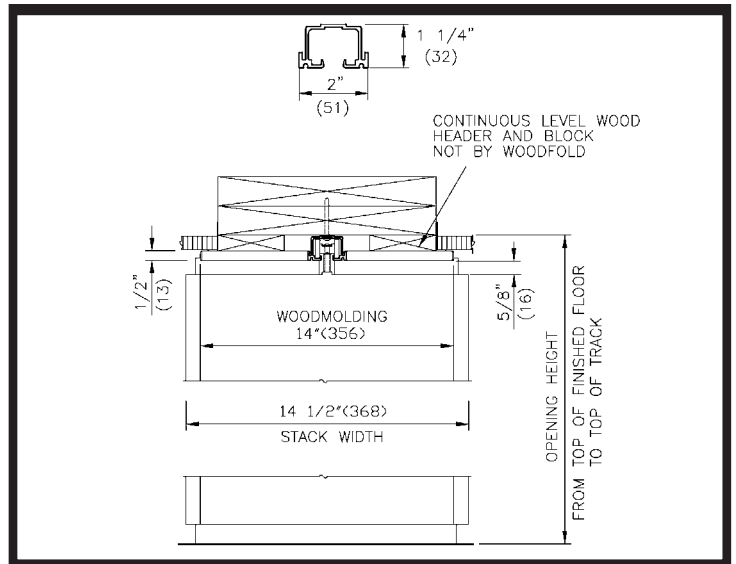

STEP 1 Continued

- H. Install wood molding at each side of track with No.6 x 1 1/2" flat head screws. Great care should be taken to assure a level surface (no side tilt) for Vinyl Sweep(sweep seal) material to contact without binding.

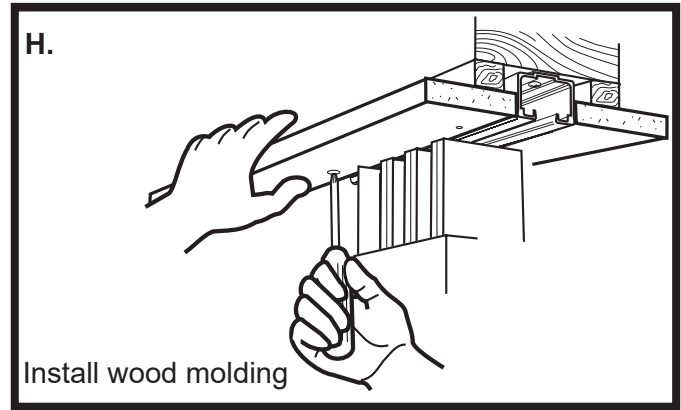

STEP 2

- A. Place jamb stud in a plumb position directly under track. Secure with No.8 x 3 1/2" flat head screws to jambs or finished wall.
- B. Carefully mate the jamb attaching panels with the secured jamb stud. See that jamb panels are snug against the finished jamb; then secure with No.6 x 1 1/2" flat head screws.

STEP 3

- A. Place jamb mold for Single-Fixed Jamb or Double-End Post Partitions in a plumb position directly under the track. Secure with No.6 x 1 1/2" flat head screws supplied. **Note: Should it become necessary to shorten the jamb mold, cut off from top only.**

STEP 4

- A. Bottom Vinyl Sweep may be adjusted for proper floor contact. To adjust, extend and latch partition. Loosen retaining bolts and pull down on bottom sweep seal until it contacts the floor evenly. **BE AWARE!** Sweep will fully disengage if extended more than 1/4". Tighten retaining bolts. Repeat procedure on the other side of partition.

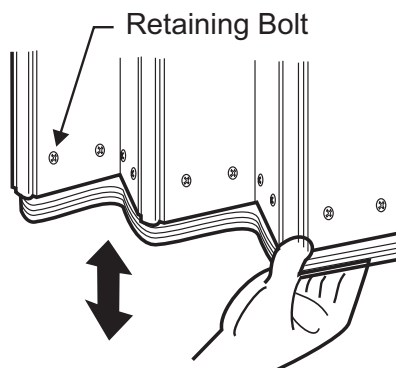

Bottom Vinyl sweep adjustment

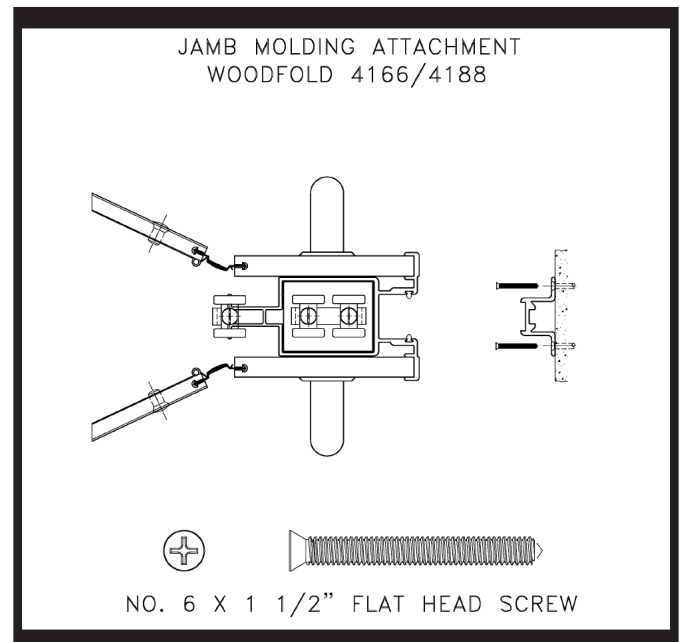
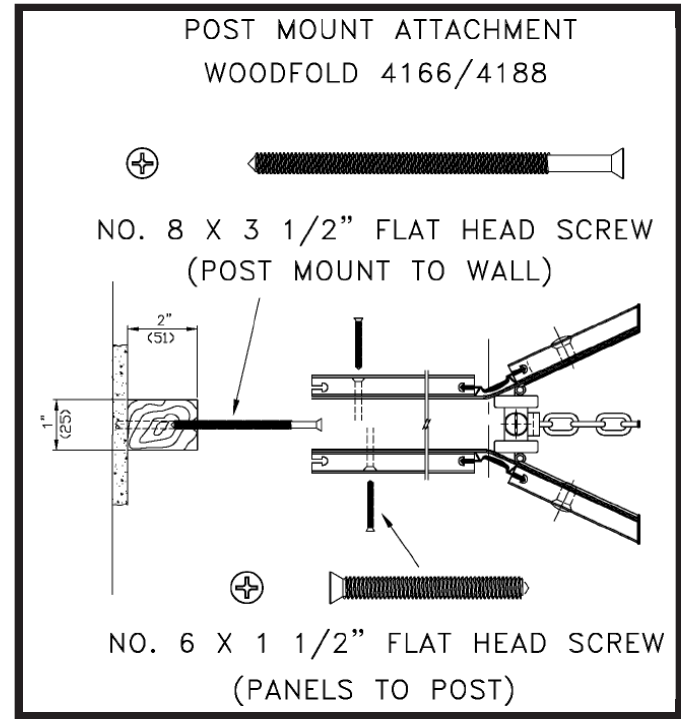

SECTION 2

Installation of Double Partitions

- A. Follow STEPS 1A through 1F except placing both partitions opposing each other directly under one half of opening,
- B. Thread first half of track onto wheels of both partitions and begin installing track screws as in **STEP 1G**.
After securing all track screws in one half of track, install second half of track. Move second partition to second half of track.
- C. Follow partition installation **Step 2 through Step 4**

If multiple pieces of track are supplied, use the (two) supplied install aligner pins to ensure accurate alignment.

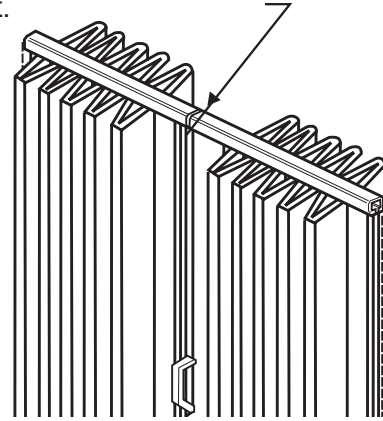

SECTION 3

Assembly of Partitions Shipped in Sections

If the partition is over 150 sqft it will be shipped in sections. It will be necessary to connect the sections after the installation onto the track.

- A. Follow STEPS 1, 2 & 3 for each of the sections. Ensure the connecting sections are oriented on the track correctly (i.e routed grooves facing other). Then attach the chain connecting the sections.
- B. Secure the sweep seals top and bottom by loosening retaining bolts on both sides and inserting the sweep seals between support brackets and panels, leaving 1" of gap between the connecting panel edges.

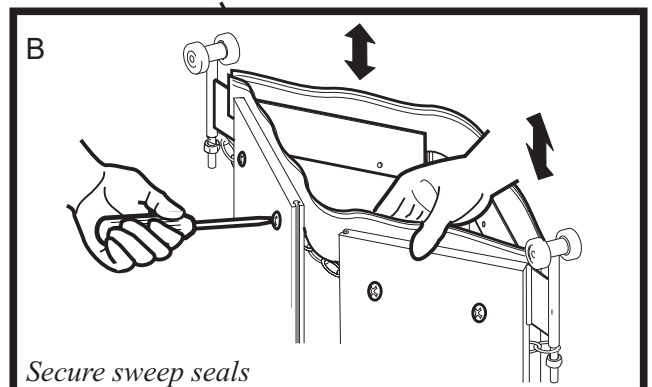
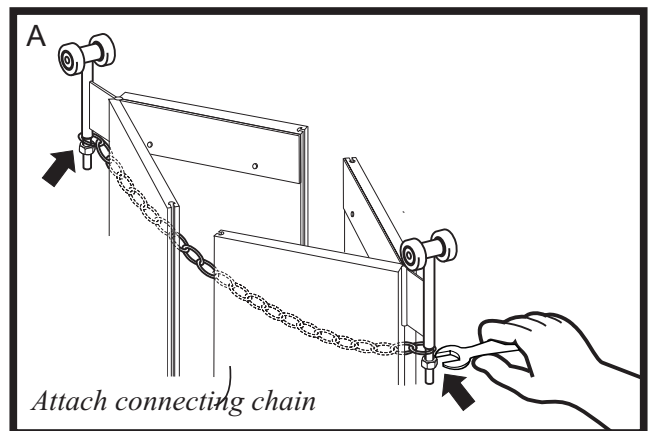

SECTION 3 Continued

C. Insert the dual-walled vinyl hinges through the routed section in the center



D. Ensure the beads of the hinge feed through the routed access grooves. Continue to feed the hinge until it is approx 1" above the top of the panel.



E. Fold the lower part of the hinge and feed into the access groove and feed to the bottom of the panel.

Stretch the lower hinge tight to ensure the hinge edges are in securely located.

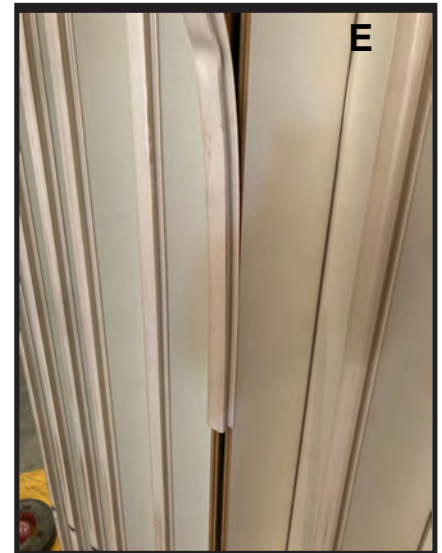
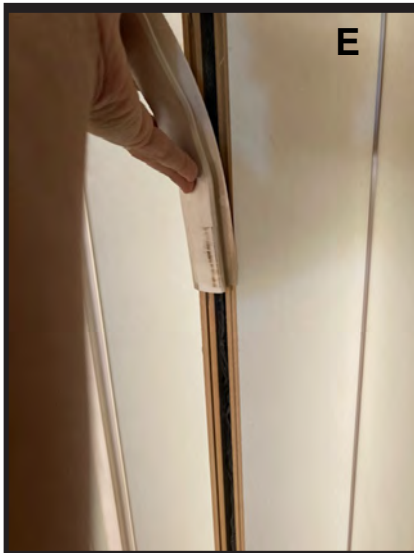

SECTION 3 Continued

- F. Staple hinges into position.
- Lift hinge flap to expose groove
 - Angle the nose of the staple gun under the flap and staple through hinge leg and the stay within the MDF panel
 - Staple above and below the routed section on all connecting panels (both sides of the partition).



- G. Trim top and bottom to be flush with the panel edges

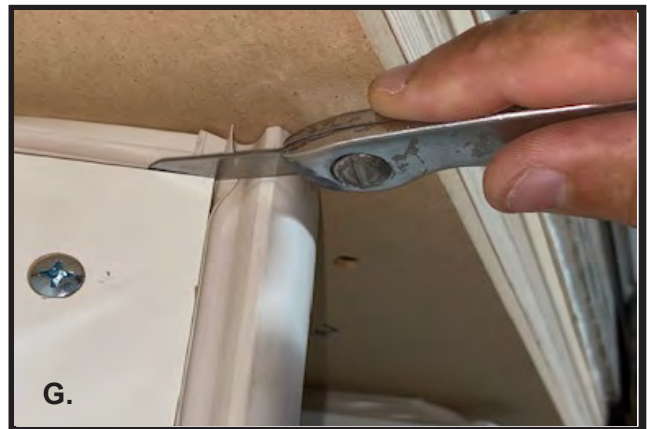

Repeat process across all sections and both sides, to complete the partition assembly and set up

Finally, adjust the bottom vinyl acoustic sweep - see STEP 4 (page 4)

CAUTION:
NEVER STORE ON END
Keep in crate until ready to install

Available Resources

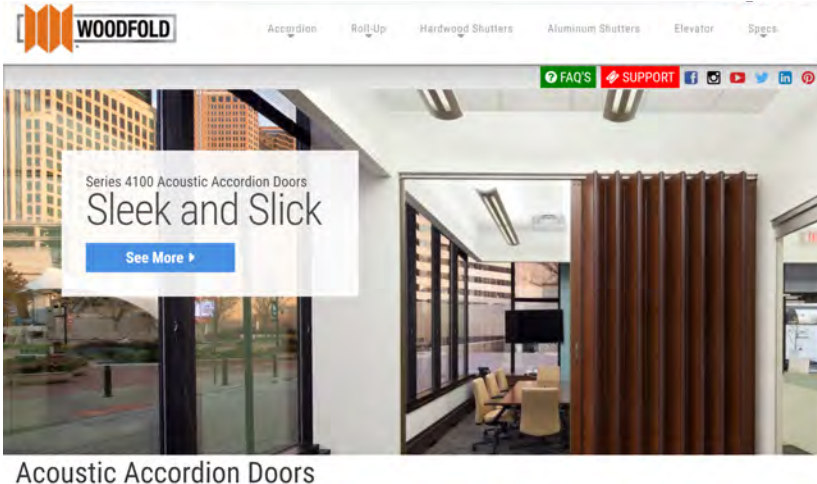

Our website is updated whenever new or revised information is published:

- Access shop drawings via 'specs' tab
- Downloadable tech bulletins
- Downloadable finish swatches
- Download 4100 order forms
- Links to our picture portfolio

Acoustic Accordion Doors



A range of items are available, either free or cost:(plus shipping)



- Finish swatches - printed copies
- Tech bulletins
- Folding hand samples
- Sample vinyl/panel swatch sample bag



The employee-owners at Woodfold thank you for your partnership and business.
Our facility in Forest Grove is our sole manufacturing center for our 100% USA made product.



Woodfold Manufacturing Inc.

1811 18th Ave. Forest Grove OR 97116

Phone (503) 357 7181 FAX: 503-357-7185

www.woodfold.com e-mail: woodfold@woodfold.com

