

## Surface Track

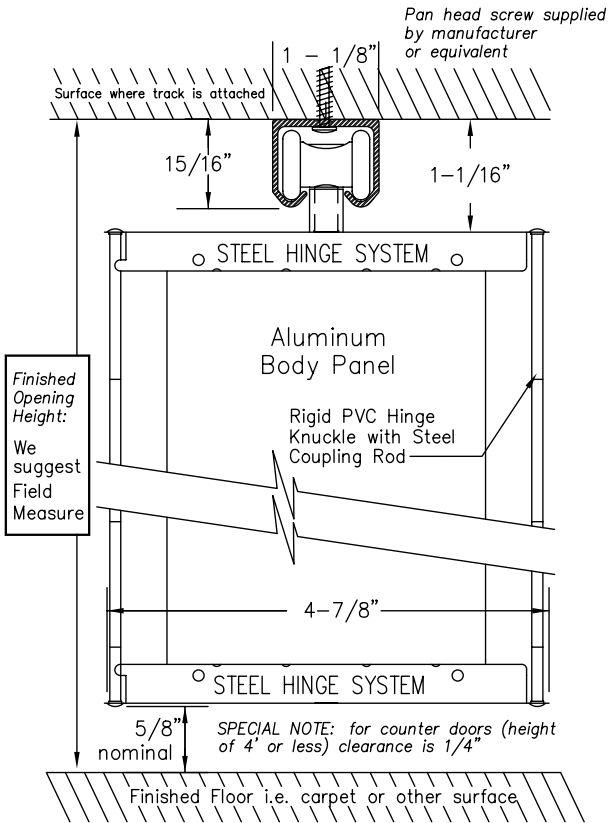

## Recessed Track

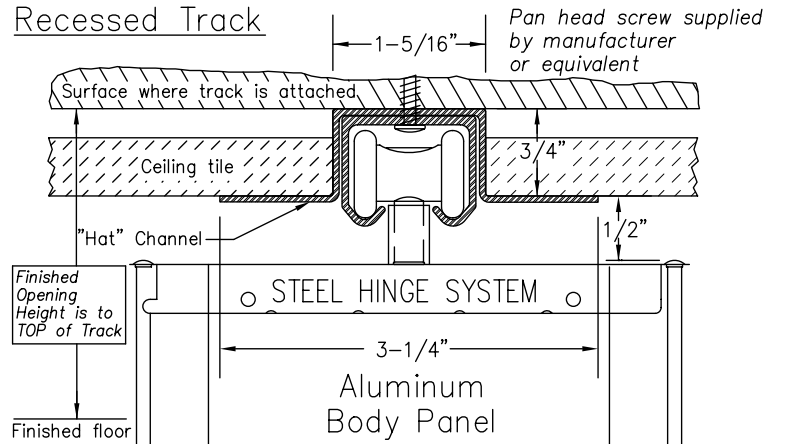

## I-Beam Track

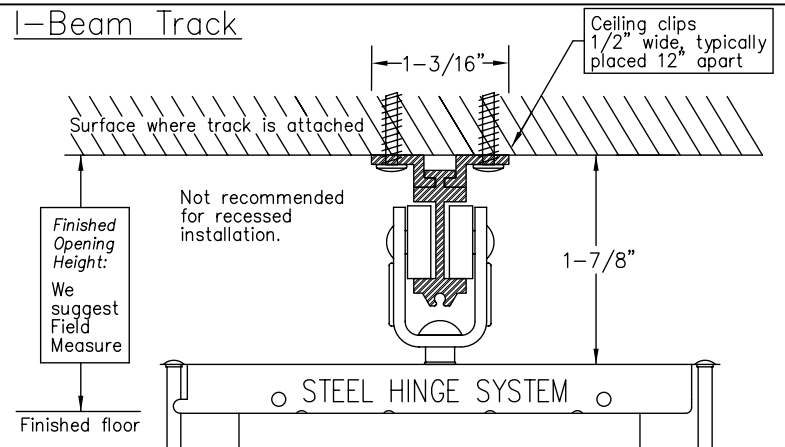

## Door Types

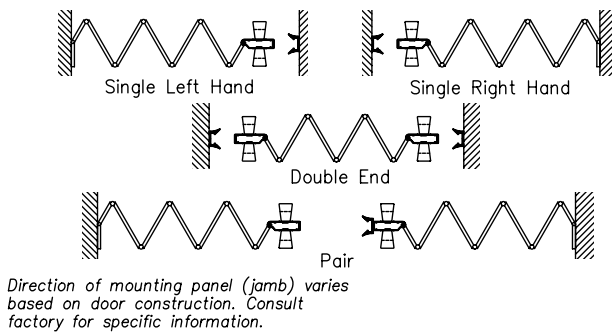

## Lead Post, Jamb Moulding & Handle

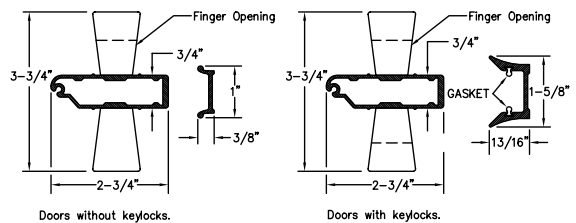

## Sliding Jamb Option

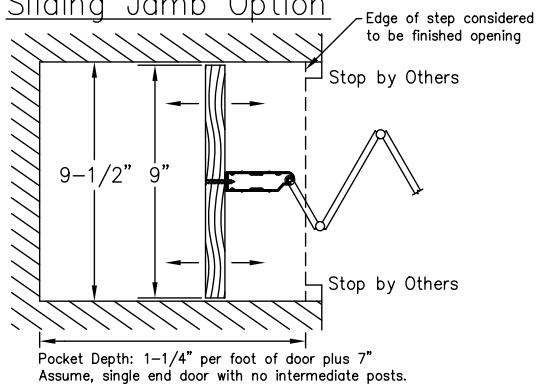

## Mounting Panel

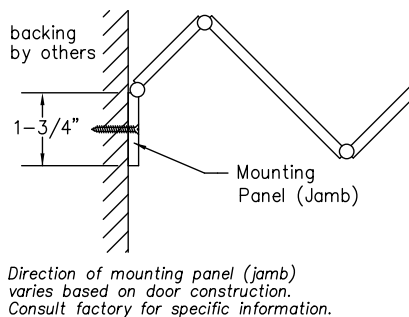

## Multiple Meeting Option

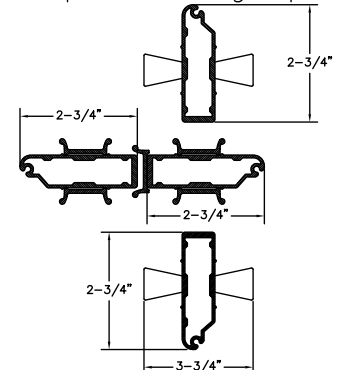

### Stack Dimensions

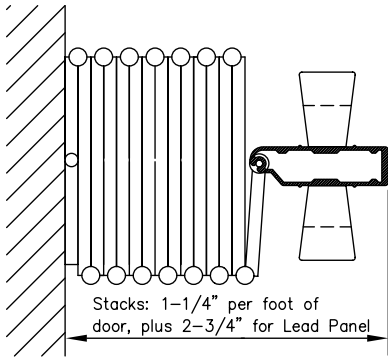

### Intermediate Rolling Post

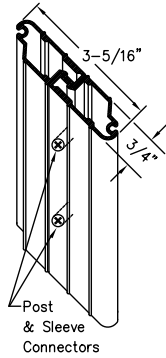

### Privacy Latch



### Keylock

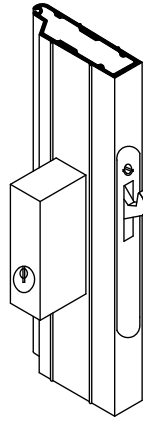

### Single Cremone Bolt Keylock

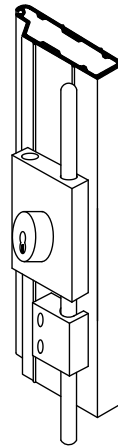

### Double Cremone Bolt Keylock

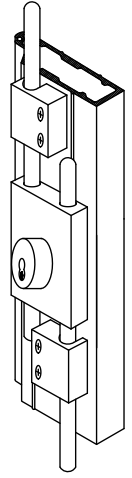

### INFORMATION

Width	Custom made to any width
Height	Custom made to 10' - 1"
Panels	Aluminum: Solid or Perforated
Side Channel	Aluminum: Clear
Panel Connector	Rigid Vinyl: Clear
	Coordinated with side channel
Hinge System	Steel: Clear
Wheels	Ball bearing nylon wheels on steel axles
Track	Aluminum (straight or curvable): Clear
Recessed Channel/ "Hat" Channel	Aluminum (straight only): White
Lead, Intermediate and Jamb	Aluminum: Clear
Latch	Deadlatch with Key Lock two sides
Header	Construction Details by Others
Door Weight	<u>Height</u> <u>Average Weight</u>
	6'-8"                              10lbs. Per lineal foot
	8'-1"                              12lbs. Per lineal foot
	10'-1"                             15lbs. Per lineal foot

### Catch/Lock Options

Magnet	Magnet with strike plate
Privacy Latch	Deadlatch with thumb turn one side
Springlatch	Springlatch with thumb turn two sides
Keylock 1 Side	Deadlatch with thumb turn one side, keylock one side
Key and Single Bolt	Key and single bolt lock
Key and Double Bolt	Key and double bolt lock
Single Cremone	Single Cremone Bolt with Key Lock
Double Cremone	Double Cremone Bolt with Lock
Footbolts	Locking or non locking
Other Keyed Options	Keyed alike, custom keyed, construction core Contact manufacture for more details

Job Name: \_\_\_\_\_ Architects Acceptance

Job Location: \_\_\_\_\_

Supplier: \_\_\_\_\_

See Woodfold Accordion Door brochure for additional details

Qty.	Single/Pair	Single End/Double End	Left or Right Stack	Width X Height	Finish/Color	Comments

THESE SPECIFICATIONS ARE SUBJECT TO CHANGE WITHOUT NOTICE